



**AUSTRALIAN 'WORLD RULES'
FOR
BRP-ROTAX
FR 125 MAX DD2
TECHNICAL SPECIFICATIONS**



VERSION 8 / 2013
UPDATED JUNE 7th, 2013



BRP-ROTAX FR 125 MAX DD2 TECHNICAL SPECIFICATIONS

Preamble:

The following are the Technical Specifications for the BRP-ROTAX FR125 MAX DD2 engine, as approved by the Australian Karting Association.

This engine is approved for use in the following classes;

FR 125 MAX DD2:

Open Performance

Unless otherwise specified, the engines must be original in all their components according to the ROTAX FR 125 MAX DD2 drawings.

Any removal, addition or polishing of material is strictly forbidden.

Sandblasting, glass bead blasting, peening, acid etching, spark eroding and/or any other method of metal removal or displacement is not allowed.

The use of thermal barrier coatings/ceramic coatings on or in the engine and on or in the exhaust system is prohibited.

The use of anti-friction coatings in or on the engine/engine components is prohibited.

The only exceptions to this are the glnisil coating of the cylinder bore and the coating to the piston skirt.

Customizing the cylinder head cover by painting is legal

ANY ALTERATIONS / MODIFICATIONS ARE STRICTLY PROHIBITED EXCEPT AS SPECIFICALLY AUTHORISED WITHIN THESE SPECIFICATIONS.

IF THESE SPECIFICATIONS DO NOT SAY YOU CAN MAKE A MODIFICATION, THEN YOU CANNOT.

Neither the engine nor any of its ancillaries may be modified in any way. "Modified" is defined as any change in form, content or function that represents a condition of difference from that originally designed. This is to include the addition and/or omission of parts and/or material from the engine package assembly unless specifically allowed within these rules. The adjustment of elements specifically designed for that purpose shall not be classified as modifications, i.e. carburetor and exhaust valve adjustment screws.

Genuine ROTAX components only, that are specifically designed and supplied for the FR 125 MAX DD2 engine are legal, unless otherwise specified.

ANYTHING WHICH IS NOT EXPRESSILY ALLOWED IN THE TECHNICAL REGULATIONS IS FORBIDDEN.

FOR USE IN AUSTRALIAN RACING, EVERY ENGINE MUST HAVE THE OFFICIAL FORMULA ROTAX AUSTRALIA STAMP ON THE CRANKCASE AND ALSO ON THE REED BLOCK FACE OF THE CYLINDER.

Internal additions:

No additional material may be added except in the case of engine repairs and shall only restore the engine or components to original specifications.

Legal additions:

Chain guard, engine mount, temperature gauge and tachometer/hour meter, inline fuel filter, catch can mounting brackets and supplemental ignition coil mounting brackets, within the limits specified in this document.

Non-tech items:

Battery, Fuel Filter, Radiator Hoses, Clamps, Pulse Line, Switches, Ancillary Mounts, Fasteners, Circlips, Washers, Bearings, Spark Plugs, Gaskets, O-Rings, Piston Pin, Springs, Seals, Clutch Drum, Engine Sprocket, Starter Motor, Clutch Flywheel, Thermostats and Housings, unless otherwise specified. Clutch Drum Evolution (AKA #48 approved Part ID #659154)



Note:

When taking any dimensional reading, of the following technical regulation, in the order of accuracy of 0,1 mm or even more precise, the temperature of the part must be between +10°C and +30°C.



It is the responsibility of the competitor to check his equipment (all components outside the engine seal and mentioned below), to assure that his equipment is in line with the technical specification below!

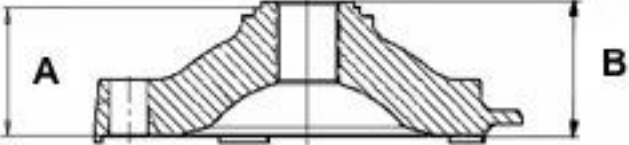



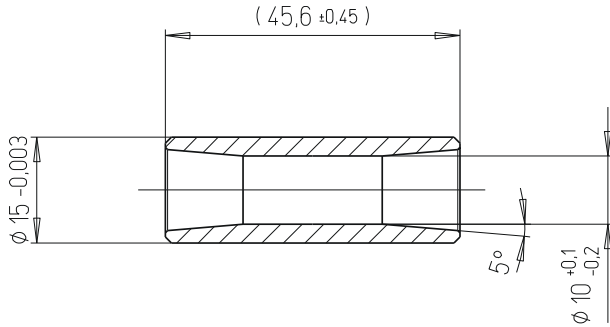

BRP-ROTAX FR 125 MAX DD2 TECHNICAL SPECIFICATIONS

Technical Specification (within the engine seal) for ROTAX kart engine FR 125 MAX DD2 (24 kW)		
Squish gap	1.1 1.2	FR 125 MAX DD2 1.10 mm – 1.50 mm The squish gap must be measured with a certified slide gauge and by using a 2 mm tin wire. The crankshaft must be turned by hand slowly over TDC (top dead center) to squeeze the tin wire. The squish gap must be measured on the left and right side in the direction of the piston pin. The average value of the two measurements counts. Recommended 2mm tin wire : part no. 580 130
Combustion chamber insert	2.1 2.2	Cast identification code has to be "223 389" or "223 389 1" or "223 389 2" Casted wording "ROTAX" and/or "MADE IN AUSTRIA" must be shown.
	2.3	Heights of combustion chamber insert have to be 27,55 mm with a tolerance of +0,0/-0,1 mm (A) and 28,80 mm with a tolerance of +/- 0,2 mm (B).
	2.4	The profile of the combustion chamber insert has to be checked with a template (ROTAX part no. 277 390). The crack of light between the template and the profile of the combustion chamber insert has to be the same over the whole profile.
		<div style="display: flex; justify-content: space-around;">  </div> <div style="text-align: center; margin-top: 10px;">  </div> <div style="margin-top: 10px;">  </div> <p>NOTE: This check is just for reference. In case of doubt detailed measurements have to be performed to define conformity or non conformity.</p>
Piston with ring assembly.	3.1 3.2	Original, coated or uncoated, aluminium, cast piston with one piston ring. The piston has to show on the inside the cast wording "ELKO" (1) and "MADE IN AUSTRIA" (2). Machined areas are: Top end of piston, outside diameter, groove for the piston ring, bore for the piston pin, inside diameter at bottom end of piston and some pre-existing factory removal (3) of flashing at the cut out of the piston skirt. All other surfaces are not machined and have cast surface.
		





BRP-ROTAX FR 125 MAX DD2 TECHNICAL SPECIFICATIONS

	3.3	<p>Original, 1 mm, magnetic, rectangular piston ring. Piston ring is marked either with "E CRY K" or "ROTAX 215 547" or "<u>ROTAX 215 548</u>".</p> <div style="text-align: center;">  </div>
Gudgeon pin	4.1 4.2 4.3	<p>Gudgeon pin is made out of magnetic steel. Dimensions must be according to the drawing. The minimum weight of the gudgeon pin must not be lower than 32,10 grams.</p> <div style="text-align: center;">  </div>
Cylinder	5.1 5.2 5.3 5.4 5.5.2	<p>Light-alloy-cylinder with GILNISIL-plating. Any re-plating of cylinder is not allowed. Cylinder with one main exhaust port and two side exhaust ports. Maximum bore of cylinder = 54,035 mm (measured 10 mm above the exhaust port). Cylinder has to be marked with the "ROTAX" logo (see picture below). Cylinder with pneumatic timed exhaust valve. Cylinder has to be marked with the identification code 613 930, 613 931 or 613 933.</p> <div style="text-align: center;">  </div>



BRP-ROTAX FR 125 MAX DD2 TECHNICAL SPECIFICATIONS

	<p>5.6</p>	<p>Height of cylinder has to be 86.7 mm $-0,05/+0,1$ mm.</p>  <p>5.7.1</p> <p>All transfer ports and passages have cast finish surface except some removal (done by the manufacturer) of cast burr at the inlet passage. and exhaust port and passages. All ports have chamfered edges to prevent ring snagging. Any additional machining is not permitted. The top edge of exhaust port may show some pre-existing machining from the manufacturer. The sealing flange for the exhaust socket may show signs of machining from the manufacture.</p>  <p style="text-align: center;">TYPICAL PICTURE</p>
	<p>5.7.2</p>	<p>All ports have chamfered edges. Any additional machining is not permitted.</p>  <p>On cylinders marked 613 993 the upper edge of the central boost port may show factory machining.</p>  <p style="text-align: center;">TYPICAL PICTURE</p>

BRP-ROTAX FR 125 MAX DD2 TECHNICAL SPECIFICATIONS

	<p>5.7.3 The sealing flange for the exhaust socket may show either cast finish surface or signs of machining from the manufacturer.</p> 
	<p>5.7.4 The top edge of the exhaust port may show either just a cast finish surface... or signs of a CNC machining ... or signs of CNC machining in combination with signs of manual grinding.</p> <div style="display: flex; justify-content: space-around;"> <div style="text-align: center;">  <p>TYPICAL</p> </div> <div style="text-align: center;">  <p>TYPICAL</p> </div> </div>  <p>The exhaust port may show partial manual grinding done by the manufacturer to eliminate minor casting defects and to eliminate the NIKASIL burr at the end of the NIKASIL plating.</p>
	<p>At cylinder 613 993 exhaust port may show factory machining all around.</p>  <p>TYPICAL</p>

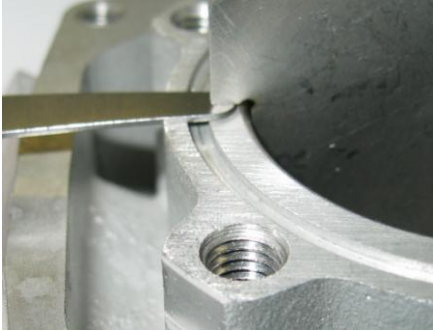
BRP-ROTAX FR 125 MAX DD2 TECHNICAL SPECIFICATIONS

	5.8	<p>Exhaust port timing</p> <p>The "exhaust port timing" (distance from the top of the cylinder to the top of the exhaust port) has to be checked by means of the template (ROTAX part no. 277 397) Insert the template into the cylinder, that the template is touching the cylinder wall and that the finger of the template is located in the middle of the exhaust port (highest point).</p> <p>Move the template upwards, until the finger is touching the top edge of the exhaust port. Insert a filler gauge between the top of the cylinder and the template. It must not be possible to fit the feeler gauge specified below.</p> <div style="display: flex; align-items: center;">  <div style="width: 200px;"> <p>FR 125 MAX DD2: 0,75 mm</p> <p>At cylinders 613 993 it is also legal if the template doesn't fit in at all.</p> <p>NOTE: Take care to use the corresponding gauge (DD2) of the template for the respective cylinder!</p> </div> </div>
Exhaust valve	5.9	<p>If the piston is moved in direction top of cylinder and first time covering completely the exhaust port, it must be possible to insert the exhaust valve gauge (ROTAX part no. 277 030) until it stops at the surface of the cylinder (a feeler gauge of 0,05 mm must not be possible to fit in).</p> 
Inlet system	6.1 6.2 6.3 6.4	<p>Inlet manifold is marked with the name "ROTAX" and the identification code "267 410"</p>  <p>Some factory flash removal may be present at the conjunction of the inside contour and the carburetor stop mounting face. This is a manual trimming operation consisting of a small corner break of less than 3 mm in width. No additional grinding or machining is permitted.</p> <p>The reed valve assy. is equipped with 2 petal stops and 2 reeds, each having 3 petals.</p> <p>The thickness of the reeds is 0,6 mm +/- 0,08 mm.</p>

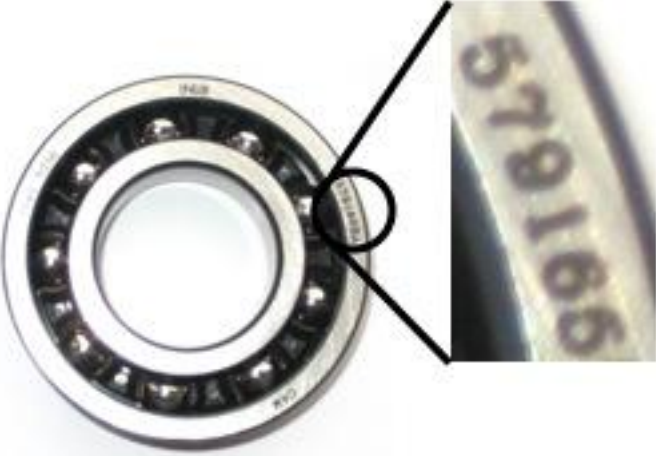

BRP-ROTAX FR 125 MAX DD2 TECHNICAL SPECIFICATIONS

Crankshaft	7.1	Stroke 54,5 mm +/-0,1 mm
	7.2	Con rod has to show forged numbers "213", "365" or "367" on shaft. 
	7.3	Shaft of con rod is not machined (copper plated). Grinding or polishing of shaft of con rod is not permitted.
	7.4	Crankshaft main bearing 6206 from FAG only is allowed. (must be marked with code 579165BA or Z579165.11.KL) 
2-speed gearbox	8.1	Primary shaft with 19 teeth for 1st gear and 24 teeth for 2nd gear.
	8.2	Idle gear for 1st gear has to have 81 teeth.
	8.3	Idle gear for 2nd gear has to have 77 teeth.
Crankcase	9.1	As supplied by the manufacturer. No grinding/polishing is permitted in the two main transfer passages as well as in the crank area.

BRP-ROTAX FR 125 MAX DD2 TECHNICAL SPECIFICATIONS

Technical Specification (outside the engine seal) for ROTAX kart engine FR 125 MAX DD2 (24 kW)

It is the responsibility of the competitor to check his equipment (all components outside the engine seal and mentioned below), to assure that his equipment is in line with the technical specification below!



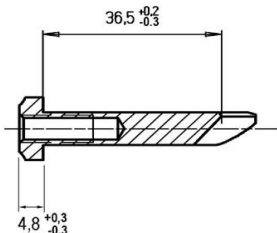

Ignition system	10.1	DENSO digital battery ignition, variable ignition timing, no adjustment necessary and possible. Race officials may request at any time that the competitor replace the ignition coil with a new unit provided by the race administration.
	10.2	The casting of the ignition coil has to show the following in casting "129000-" and "DENSO".
	10.3	Ignition coil must show 4 or 6 pins at the terminal.
	10.4	Connector housing of ignition coil must have either white or grey colour. There is also a legal version with number "266750" see below picture)
		
	10.5	The ignition coil has to be fixed by means of 2 original silent blocks to the crankcase. Only in case of chassis component interference with the original mounting location of the ignition coil, a supplementary extension bracket, rigidly constructed and fabricated of solid metal, of minimum dimensions and attached to the original case mounting holes, is permitted for mounting of the coil.
	10.6	Minimum length of ignition wire (high tension wire) is 210 mm from outlet of cable at ignition coil to outlet of cable at spark plug connector (= the visible length of wire) Ignition coil must be in working condition (to be tested in case of doubt)
	10.7	The pick up must be marked with the numbers 029600-0710, followed by a variable production code in the 2nd line. HINT: In case of doubt an easy check is to place a steel ball (3-5 mm in diameter) on the pickup (engine side), the steel ball must stay in the center of the pickup surface.
	10.8	Spark plug cap must be marked with "NGK TB05EMA".
	10.9	Battery must be fitted to the chassis with at least 2 screws. Position of the battery is free.
10.10	The earth strap may be fitted with a connector for ease of removal of the engine. Rotax Wiring Harness to be OEM only, no fittings, no repairs. The ignition coil can be relocated from the crankcase as far as the OEM harness will permit.	
		
Exhaust valve	11.1	As supplied by the manufacturer with no modification allowed. Compression spring must be fitted.
	11.2	Length of the exhaust valve is 36,5 mm +0,20 mm /-0,30 mm.
	11.3	Width of collar is 4,8 mm +/-0,3 mm
	11.4	Any adjustment or blocking to this valve once the engine is running is illegal.

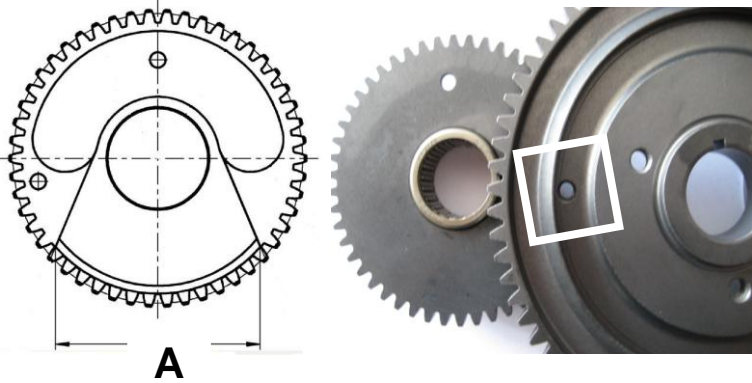
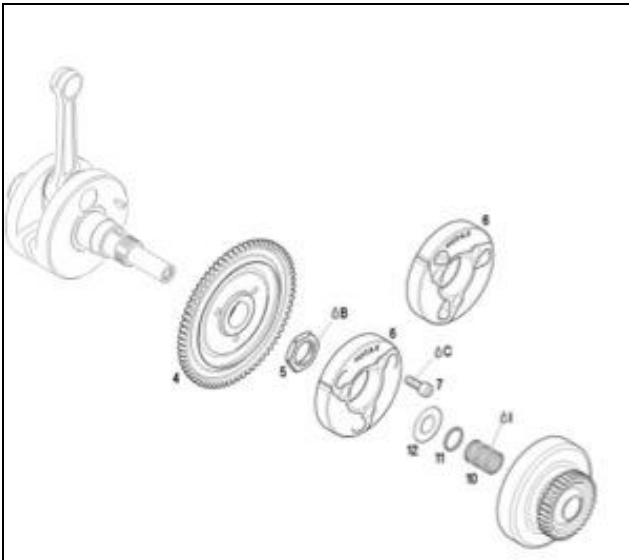

BRP-ROTAX FR 125 MAX DD2 TECHNICAL SPECIFICATIONS

<p>Balance drive</p>	<p>12.1 12.2 12.3 12.4 12.5 12.6</p>	<p>Balance drive gear must be fitted on crank shaft. Balance gear must be fitted on primary shaft and must be aligned with the balance drive gear according to the instruction in the repair manual. Fly weight of balance gear must show cast surface (old version only)</p>  <p>New version</p>  <p>Fly weight of balance gear can show machined surface (new version only). Dimension A (widest part of balance weight) must be either 53 mm +/- 0,5 or <u>57</u> mm +/- 0,5</p> <p>The minimum weight of a dry balance gear including bearing (new version only) must not be lower than 240 grams</p> <p>Balance drive gear compartment must be vented and connected to a minimum 100ml plastic overflow bottle via plastic hose.</p>
<p>Centrifugal clutch</p>	<p>13.1</p>	<p>Dry centrifugal clutch, engagement r.p.m. maximum at 4.000 r.p.m. That means, that the kart (without driver) must start to move latest at an engine speed of maximum 4.000 r.p.m. Both clutch element versions as in illustration are legal to be used. Old version clutch element can be either untreated or nitrated configuration.</p> 

BRP-ROTAX FR 125 MAX DD2 TECHNICAL SPECIFICATIONS

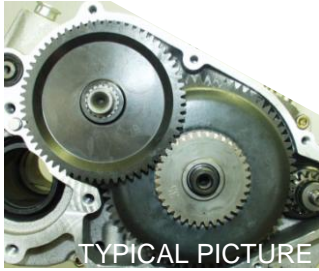
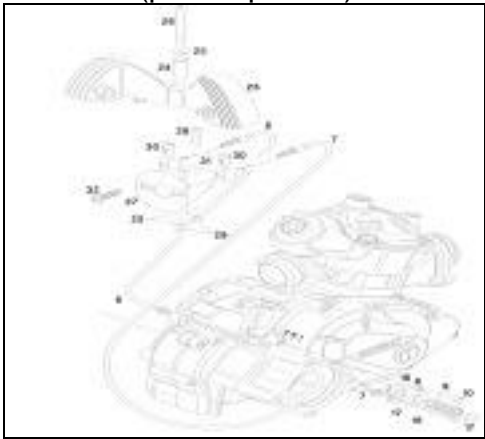
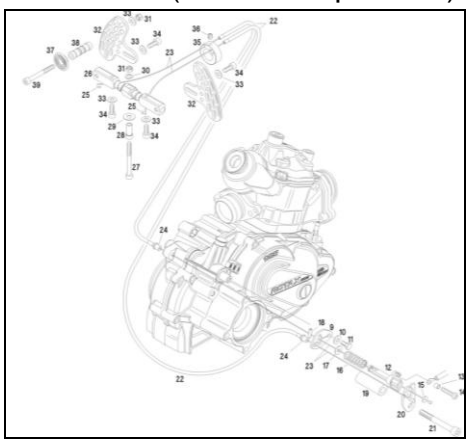

13.3	Steel clutch (both versions) and clutch drum must be within following specifications.
13.3.1	<p>Height of Clutch</p>  <p>Minimum: 14.45 mm.</p>
13.3.2	<p>Thickness of clutch shoe</p>  <p>Measurement has to be done at the 3 open ends of the clutch shoes, 5 - 10 mm from the machined groove (all clutch shoes must be completely closed at measurement - no gap).</p> <p>No measurement may be below 24.10 mm.</p>
13.3.3	<p>Outer diameter of clutch drum</p>  <p>Diameter has to be measured with a sliding caliper just beside the radius from the shoulder (not at the open end of the clutch drum).</p> <p>Minimum diameter: 89.50 mm.</p>
13.3.4	<p>Inner diameter of clutch drum</p>  <p>The inner diameter has to be measured with a sliding calliper. The measurement has to be done in the middle of the clutch drum (in the contact area of the clutch drum).</p> <p>Maximum diameter: 84.90 mm.</p>

BRP-ROTAX FR 125 MAX DD2 TECHNICAL SPECIFICATIONS



	13.3.5	Height of sprocket with clutch drum assembly.		<p>Minimum height: 39.50 mm</p>																	
Primary drive	14.1	<p>Original primary drive gears of following gear ratio options must be used. Only mentioned pairs are legal to be used</p> <table style="margin-left: 20px; border-collapse: collapse;"> <thead> <tr> <th style="text-align: left;">Drive gear</th> <th style="text-align: left;">Driven gear</th> </tr> </thead> <tbody> <tr><td>32</td><td>65</td></tr> <tr><td>33</td><td>64</td></tr> <tr><td>34</td><td>63</td></tr> <tr><td>35</td><td>62</td></tr> <tr><td>36</td><td>61</td></tr> <tr><td>37</td><td>60</td></tr> <tr><td>38</td><td>59</td></tr> </tbody> </table>	Drive gear	Driven gear	32	65	33	64	34	63	35	62	36	61	37	60	38	59	 <p style="text-align: center; font-size: small;">TYPICAL PICTURE</p>	14.2	<p>A specific primary gear ratio may be determined for each race event by a "Supplementary Regulation".</p>
Drive gear	Driven gear																				
32	65																				
33	64																				
34	63																				
35	62																				
36	61																				
37	60																				
38	59																				
Gear shifting	15.1	<p>The 2-speed gearbox has to be operated with the one of the 2 available original supplied shift paddle configurations on the steering wheel via the two cable bowden</p>		15.2	<p>Cutting of the original shift paddle or adding of pads to the shift paddle is allowed to adjust the paddle to specific steering wheels (for plastic paddle only) For aluminium paddle version no cutting or adding of non original parts or material is allowed.</p>																
	15.3	<p>Original hub for steering wheel must be used (for plastic paddle only)</p>			<p>Version 1 (plastic paddle)</p> 																
					<p>Version 2 (aluminium paddles)</p> 																

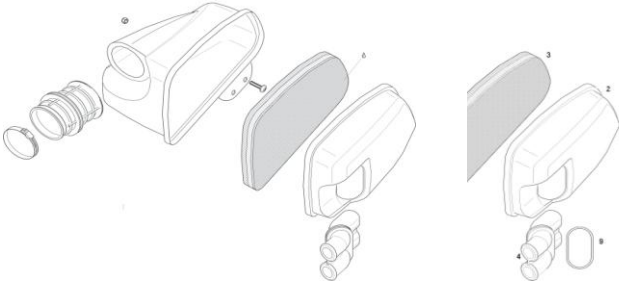



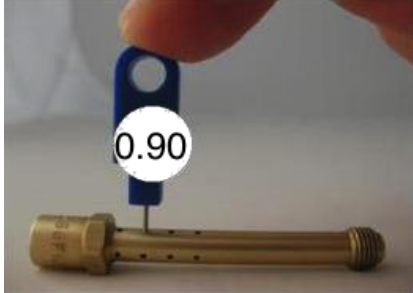

BRP-ROTAX FR 125 MAX DD2 TECHNICAL SPECIFICATIONS

<p>Intake silencer</p>	<p>16.1 16.2 16.3 16.4 16.5 16.6</p>	<p>Intake silencer with integrated, washable air filter as shown in illustration below (2 legal versions available).</p> <p>The intake silencer case is marked on the inside with the ROTAX part no. 225 012.</p> <p>The intake silencer cover is marked on the inside with the ROTAX part no. 225 022.</p> <p>The air filter is marked with the ROTAX part no. 225 052.</p> <p>The air filter must be assembled between the intake silencer case and the intake silencer cover that the whole area of the intake silencer case is covered.</p> <p>In case of a wet race it's allowed to seal the top of the airbox using adhesive tape.</p> <p style="text-align: center;">Version 1 (without o-ring) Version 2 (with o-ring)</p> 
<p>Carburettor</p>	<p>17.1 17.2 17.3 17.4 17.5 17.6 17.7 17.8 17.9 17.10 17.11 17.12</p>	<p>DELL'ORTO carburettor .</p> <p>VHSB 34" cast in the housing of the carburettor.</p> <p>"QD" or "QS" stamped in the housing of the carburettor.</p> <p>The complete inlet bore in the casting of the carburettor must show cast surface.</p> <p>The carburettor slide must show with size "40" in casting and the bottom end of the slide must show cast surface.</p> <p>Jet needle stamped with "K98" only</p> <p>Settings of the carburetor adjustment screws are free.</p> <p>Following two combinations of floats and idle jets are legal:</p> <p><u>Combination 1:</u> For carburettor insert 12.5 (as per illustration at rule 15.17) Floats are marked with "5.2gr" Idle jet and Idle jet insert are stamped with the digits "30"</p> <p><u>Combination 2:</u> For carburettor insert 8.5 (as per illustration at rule 15.17) Floats are marked with "3.6gr" Idle jet and Idle jet insert are stamped with the digits "60"</p> <p>NOTE: Effective from 1st January, 2014, Combination 2 only is allowed for the Rotax National Championships, Rotax Pro Tour, all State Championships and events where Rotax is run as a standalone class. This does not apply to Restricted TAG, TAG & Sportsman style classes.</p> <p>All jets must be correctly seated and securely fitted!</p> <p>A minimum required size of main jet may be determined for each race event by a "Supplementary Regulation".</p> <p>Reserved.</p> <p>Needle valve assembly stamped "150" or "200"</p> <p>Needle of needle valve marked with diamond symbol "INC" only.</p> 

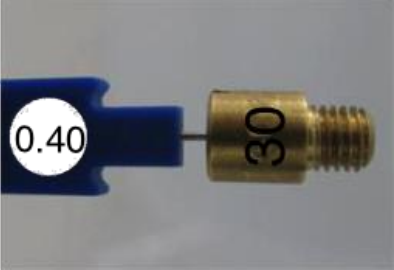

BRP-ROTAX FR 125 MAX DD2 TECHNICAL SPECIFICATIONS

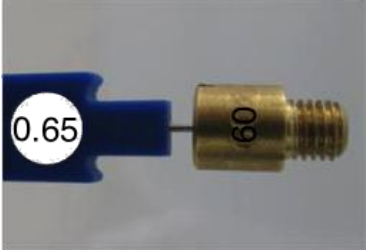
	<p>17.13 17.14 17.14.1</p>	<p>Start jet is stamped with digits "60" Needle jet stamped with "FN 266". Total length of needle jet: 54.00 +/- 0.3mm</p> 
	<p>17.14.2</p>	<p>Length of bottom section of needle jet: 11.50 +/- 0.2mm</p> 
	<p>17.14.3</p>	<p>Top bore diameter of needle jet 2.60 +/- 0.15mm</p> 
	<p>17.14.4</p>	<p>4 x 4 cross holes diameter: Plug gauge 0.90mm may not enter one of the 16 cross holes of the needle jet. (Use jet gauge set ROTAX part no. 281 920)</p> 



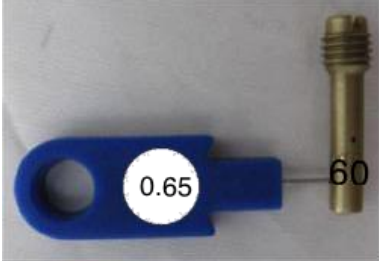
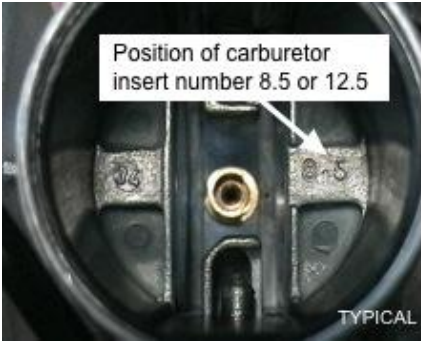

BRP-ROTAX FR 125 MAX DD2 TECHNICAL SPECIFICATIONS

	<p>17.15</p> <p>17.15.1</p>	<p>Idle jet 30 and Idle jet insert 30 must be used with carburettor insert stamped 12.5 as per illustration at 17.17.</p> <p>Plug gauge 0.40mm may NOT enter the bore of the idle jet 30. (Use jet gauge set ROTAX part no. 281 920)</p>  <p>17.15.2</p> <p>Plug gauge 0.40mm may NOT enter the bore of the idle jet insert 30 (Use jet gauge set ROTAX part no. 281 920).</p>  <p>17.15.3</p> <p>Plug gauge 0.40mm may NOT enter one of the 4 cross bores of the idle jet insert 30. (Use jet gauge set ROTAX part no. 281 920)</p>  <p>17.16</p> <p>17.16.1</p> <p>Idle jet 60 and Idle jet insert 60 must be use with carburettor insert stamped 8.5 as per illustration at 17.17.</p> <p>Plug gauge 0.65mm may NOT enter the bore of the idle jet 60. (Use jet gauge set ROTAX part no. 281 920)</p>  <p>17.16.2</p> <p>Plug gauge 0.65mm may NOT enter the bore of the idle jet insert 60 (Use jet gauge set ROTAX part no. 281 920).</p> 
--	-----------------------------	--



BRP-ROTAX FR 125 MAX DD2 TECHNICAL SPECIFICATIONS

	<p>17.16.3</p>	<p>Plug gauge 0.65mm may NOT enter one of the 4 cross bores of the idle jet insert 60. (Use jet gauge set ROTAX part no. 281 920)</p> 
	<p>17.17</p>	<p>Carburettor insert must show number stamping of either 8.5 or 12.5 as illustrated below.</p> 
	<p>17.17.1</p>	<p>Angular bore: Plug gauge 0.60 may not fit. (8.5 Carburettor Insert only) (Use jet gauge set ROTAX part no. 281 920)</p> 
	<p>17.17.2</p>	<p>Vertical bore: Plug gauge 0.90 may not fit. (8.5 Carburettor Insert only) (Use jet gauge set ROTAX part no. 281 920)</p> 

BRP-ROTAX FR 125 MAX DD2 TECHNICAL SPECIFICATIONS

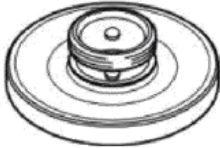

	<p>17.18</p>	<p>Position of atomizer: venturi tool set (ROTAX part no. 676034): control pin \varnothing 3.6mm must enter atomizer.</p> 
	<p>17.18.1</p>	<p>Remove atomizer from carburettor body using venturi tool set (ROTAX part no. 676034): Atomizer, total length: 23.75 +/- 0.45mm</p> 
	<p>17.18.2</p>	<p>Atomizer, length of cylindrical part: 15.75 +/- 0.25mm</p> 
	<p>17.18.3</p>	<p>Atomizer, dimension of cutaway: 6.00 +/- 0.15mm</p> 

BRP-ROTAX FR 125 MAX DD2 TECHNICAL SPECIFICATIONS

	<p>17.19</p> <p>17.20</p> <p>17.21</p>	<p>Atomizer, diameter of cross bore: 4.05 +/- 0.15mm</p>  <p>Optional carburettor plug screw marked "ROTAX" (ROTAX part no 261 030) is legal to be used.</p>  <p>The two vent fittings must be connected with the original air vent hose 180mm (ROTAX part no 260 260).</p>
<p>Fuel pump</p>	<p>18.1</p> <p>18.2</p>	<p>Original diaphragm fuel pump (grey or black color) must be fitted by means of two original silent blocks to the chassis or the engine. Optionally the MIKUNI diaphragm pump (as used on the 125 MAX engine) can be used</p>  <p>Center line of fuel pump may not be higher than the center line of the carburetor.</p>

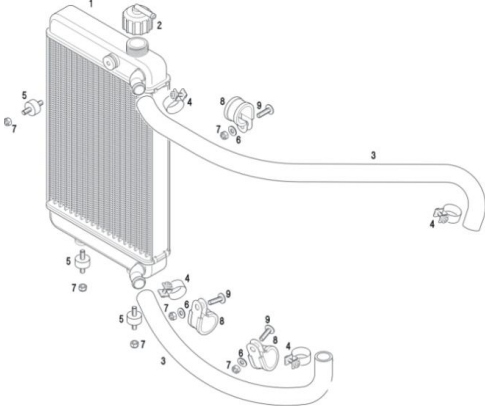

BRP-ROTAX FR 125 MAX DD2 TECHNICAL SPECIFICATIONS

<p>Radiator</p>	<p>20.1 20.2 20.3 20.4 20.5 20.6 20.7 20.8</p>	<p>Single aluminium radiator (see illustration below). Name "ROTAX" is stamped in the top/side of the radiator. Version 1: Cooling area: Height :284 mm, width:202 mm Version 2: Cooling area: Height :290 mm, width: 196 mm</p> <p>Version 1: Thickness of radiator = 32 mm Version 2: Thickness of radiator = 34 mm</p> <p>The radiator must be mounted on the left side side of the kart beside the seat. The highest point of the radiator with cap may not be higher than 400 mm above the main tube of the kart chassis.</p> <p>No additional non original cooling device is allowed For version 1 and 2 tape can be applied around the radiator. Tape may not be removed from the radiator during operation on the track. All other means of air flow control through the radiator are prohibited, except for the plastic flap on version 2. For version 2, the removal of the original plastic flap and use of tape, like for version 1 of the radiator, is an acceptable configuration.</p> <p>The removal of the thermostat from the cylinder head cover is an acceptable configuration.</p> <div style="display: flex; justify-content: space-around; align-items: flex-start;"> <div style="text-align: center;"> <p><u>Verion 1</u></p>  </div> <div style="text-align: center;"> <p><u>Version 2</u></p>  </div> </div>
<p>Radiator coolant</p>	<p>21.1 21.2</p>	<p>Glycol base or soluble oil coolants are prohibited. Radiator coolant system must be fitted with a catch tank of minimum 100ml capacity to retain radiator coolant overflow, as per rule 25.18(b).</p>

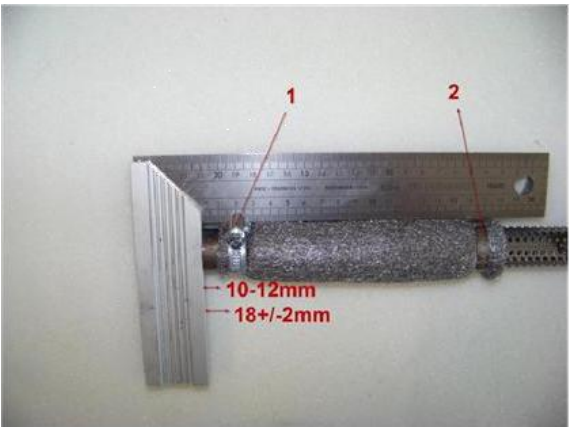

BRP-ROTAX FR 125 MAX DD2 TECHNICAL SPECIFICATIONS

Exhaust system	22.1	Must be as supplied by BRP-POWERTRAIN and cannot be modified except for the replacement of the silencer absorption material and the use of threaded fasteners in place of the rivets for securing the silencer end cap.
	22.2	Standard exhaust socket must be used.
	22.3	Exhaust pipe with after muffler as shown in illustrations. Both versions (version with welded on after muffler and version with after muffler fixed by 2 springs) are legal to be used.
		
	22.4	Diameter of hole of end cap of (pos 6, illustration above): 19.6mm +/-0.2mm
	22.5	Just one piece of original isolating mat is allowed to be used.
	22.6	Additional to the standard isolation mat a special steel isolation mat of the square dimension of 165 +10 mm is legal (not mandatory) to be assembled underneath the standard isolation mat as in following illustration (ROTAX part no. of kit 297983).
		
	<p>Clamp (1) must be fitted at a distance of 18+/-2mm, measured from the end of the tube. Clamp (2) must be fitted at the end area of the steel isolation mat.</p> <p>10-12mm is a specification for assembly purpose only! Both clamps are mandatory.</p>	
	22.7	The original exhaust system (tuned pipe and silencer) may not be modified, except for the addition of extra elements for further noise reduction.
	22.8	For measuring the exhaust gas temperature, it is allowed to weld on a socket of the exhaust <u>in an area of 50 - 80 mm</u> from the ball joint. The use of maximum 4 pieces of exhaust springs to fix the exhaust to the cylinder is allowed.
Noise emissions	23.1	Noise isolating mat (see illustration exhaust system) has to be replaced by a original BRP-POWERTRAIN spare part,